



CDC6 Specification

Contents

1、 About the user manual	2
2、 External Dimensions	2
Material and Color	2
Real product	2
Dimension figure :(unit: mm)	3
3、 Function Summary	3
4、 Button Definition	5
5、 Installation Instructions.....	6
6、 Normal Operation	6
a. Display on/off.....	6
b. Turn on/off of headlights.....	7
c. Opening/closing of USB charging function	7
d. Assisted selection and 6Km/h implementation mode	9
e. Instrument display interface	10
f. Electricity display	12
g. Error code display	13
h. Motor power display	13
7、 General Setting.....	13
(1) Wheel diameter selection	13
(2) Speed unit setting	15
8、 Cable outlet define	15
9、 Q&A.....	16
Schedule: error code definition table	17

1、 About the user manual

Dear users:

To ensure better performance of your e-bike, please read through the CDC6 inspection carefully before using it. We will inform you of all the details, including the installation and setting of the hardware and normal use of the display with the most concise words. Meanwhile, and help you to solve all the puzzles and obstacles

2、 External Dimensions

Material and Color

CDC6 products use 3.5 inch LCD display, with lightweight and beautiful buttons to use, double PCB, nylon buckle, ABS material shell. Under the temperature ranging from -20°C to 60°C , the shell material can ensure normal usage and good mechanical performance of the products.

Real product

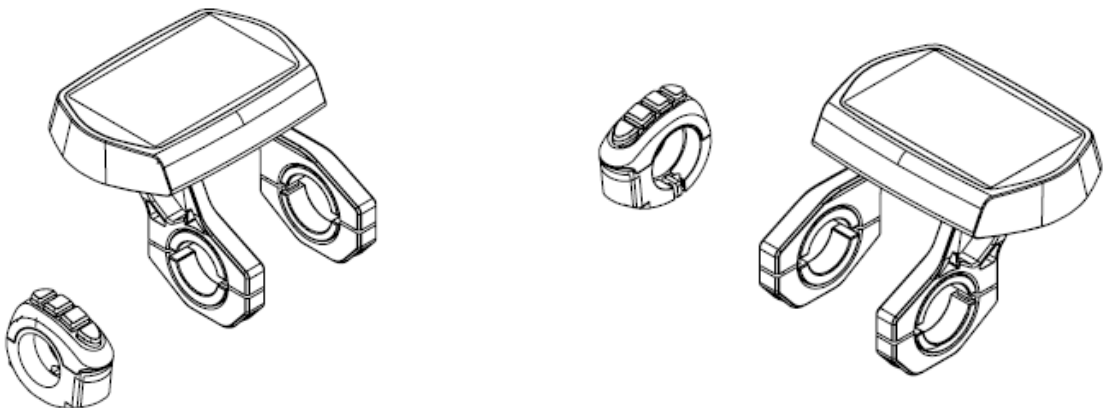



Figure 2-1

Dimension figure :(unit: mm)

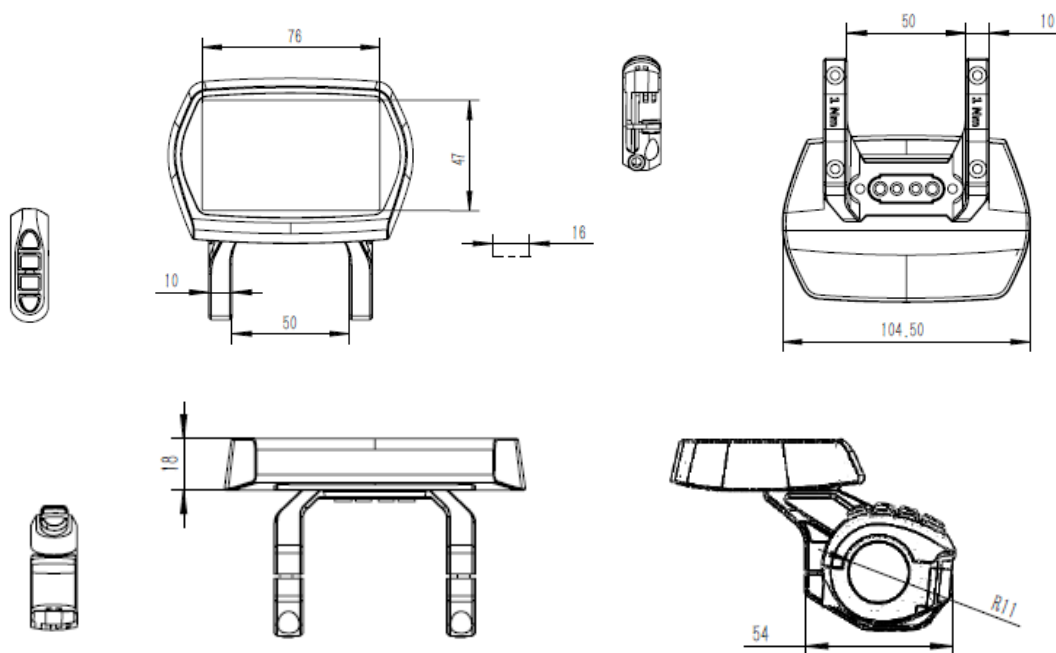

Figure 2-2

3、 Function Summary

CDC6 is a Multifunction display that integrated 3.5 inch LCD. The same display can match 24V, 36V, 48V battery. At the same time integrated 24V, 36V and 48V headlamps switch function. With another CDBL_C product of our company will

greatly simplify the handlebar cable. CDC6 function Summary (Figure in 3-1)

- ◆ Total distance indicator
- ◆ Riding distance indicator
- ◆ Current speed indicator
- ◆ Car lamp display
- ◆ PAS level selection
- ◆ Battery residual capacity indicator
- ◆ Error code definition
- ◆ Kilometers or miles
- ◆ Wheel diameter selection
- ◆ USB charging function
- ◆ Bluetooth function (customer requirement customization)
- ◆ 6Km/h implementation function

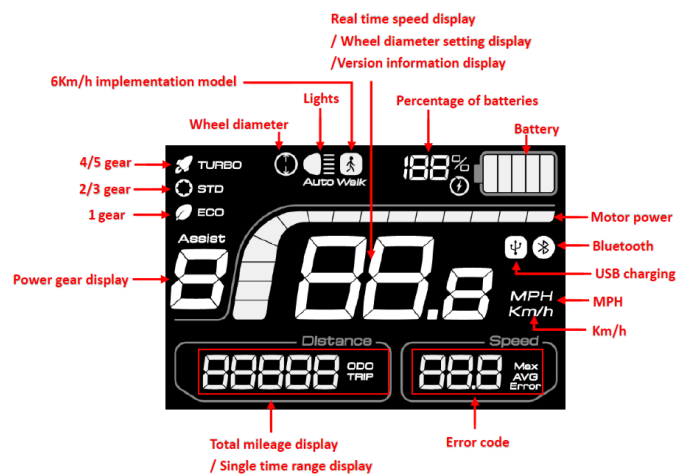

Figure 3-1

Display all

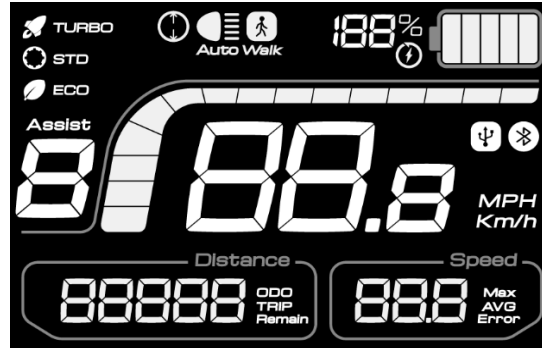

Figure 3-2

Normal Viewing Area (A backlight often lights up)



Figure 3-3

4、 Button Definition

CDC6 has four buttons including SET 、 UP、 DOWN and ON/OFF.

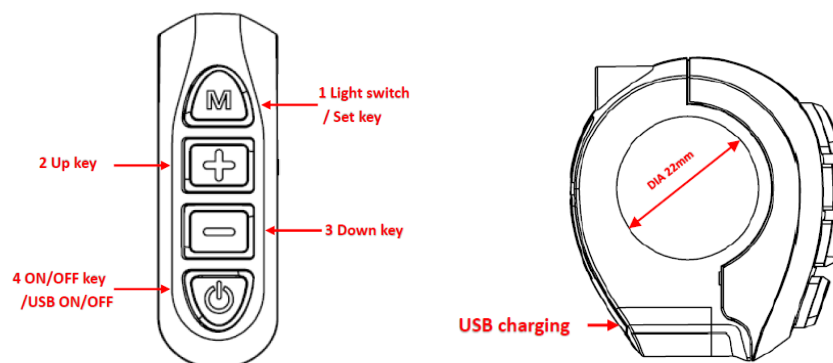
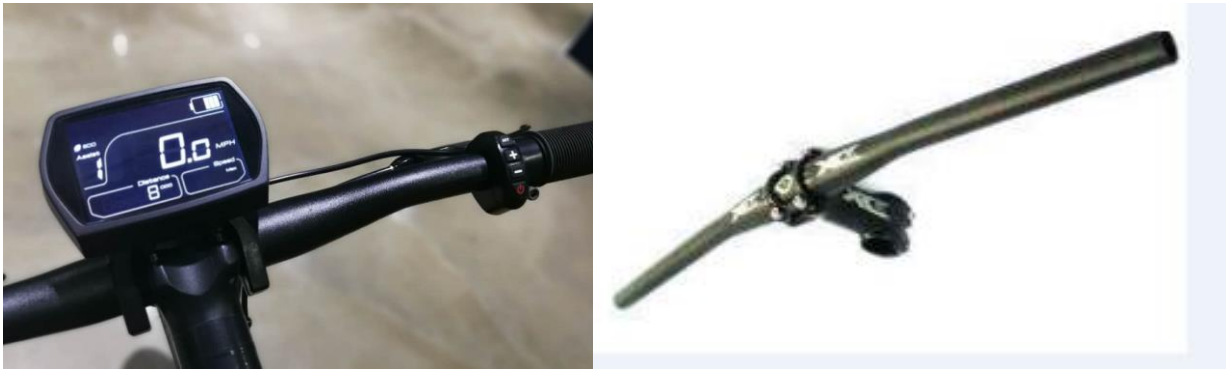

Figure 4

5、 Installation Instructions

Display will be fixed on the handlebar, and then adjust the angle of view, and will be installed in the position of the button is easy to control. Tighten the screws to complete the installation.



Insert the buckle into the vehicle



Tighten the screws to complete the installation.

6、 Normal Operation

a. Display on/off

After touching the power button, the meter starts to work and provides circuit board analog circuit working power. In the boot state, the power button will be

switched off for 3 seconds. In the shutdown state, the meter no longer USES the battery power, the meter leakage current is less than $2\mu\text{A}$. The operation process is shown in figure 6-1:

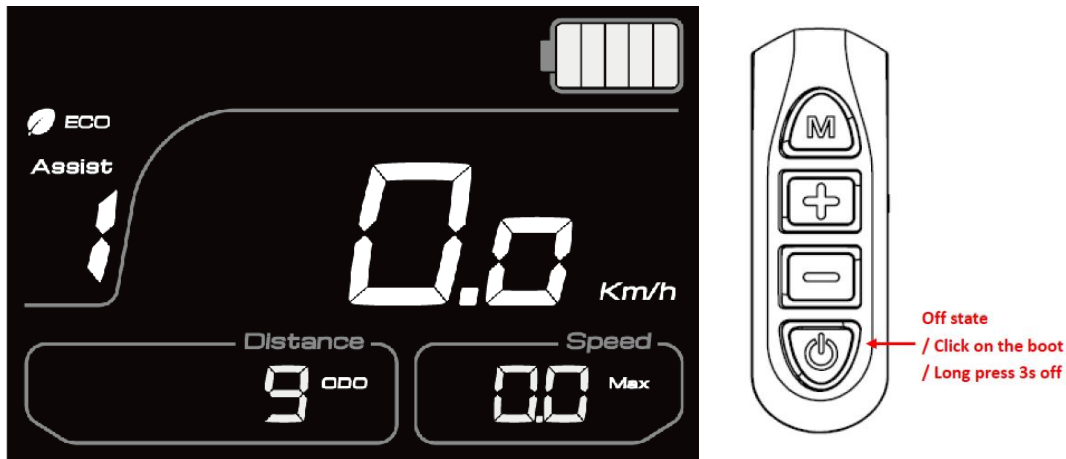

Figure 6-1

b. Turn on/off of headlights

In the startup state, press the button on the button to turn on the light, and then press the boot button, then the headlights are closed. The operation process is as shown in figure 6-2 :(the lights are on)

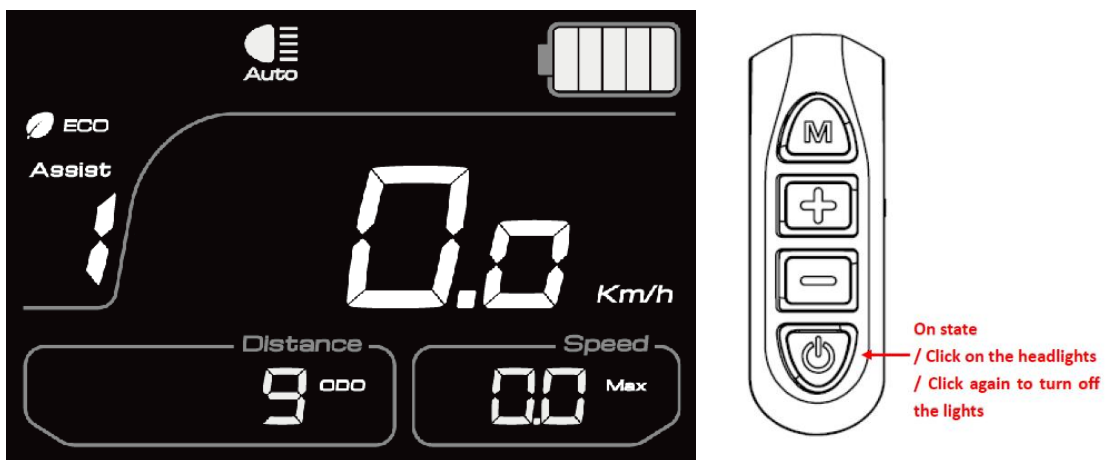

Figure 6-2

c. Opening/closing of USB charging function.

In the boot state, press the button to set up the USB charging function, and then press the Settings button, then the USB charging function is closed. Long press the set key to enter the setting mode, can set its wheel speed and other information. The operation process is shown in figure 6-3 below: (USB open state)

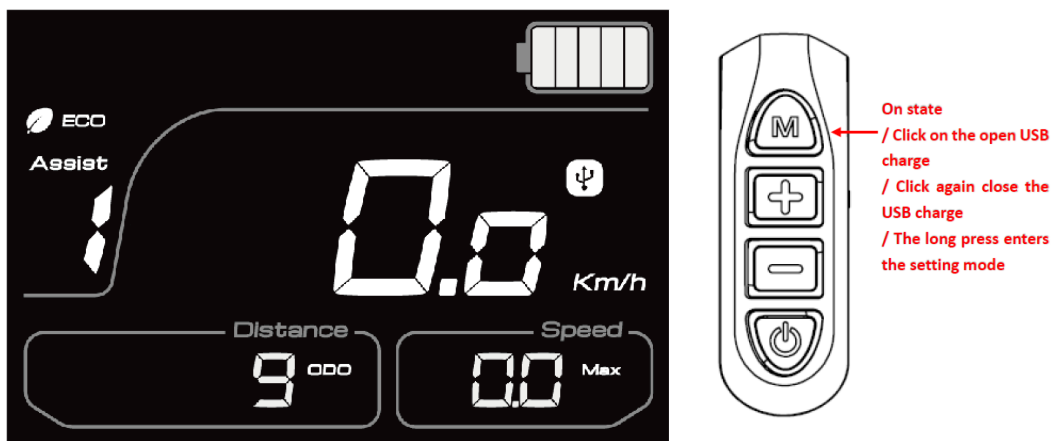

Figure 6-3

d. Assisted selection and 6Km/h implementation mode.

In the startup state, click the up and down button, switch the power of electric power, change the output power of the motor, and the default output power range of the meter is 0-5, which is adjustable. The long press down key will enter the implementation mode of 6Km/. The operation process is shown in figure 6-4: (6Km/ implementation mode)

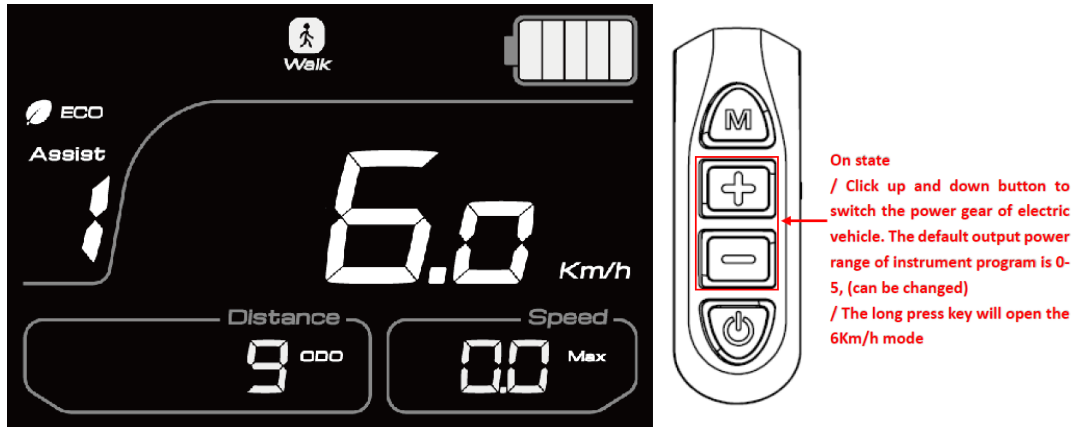

Figure 6-4

e. Instrument display interface.

In the operation of the electric moped, circuit board speed monitoring device to detect speed values, to screen for display, the speed sensor, speed sensor will rotate speed signal sent to the controller, the controller will adjust the motor speed, motor speed controller will feedback to the instrument at the same time. Display on display: real-time speed, total mileage, single time mileage, power-assisted gear, power, error code, current information and other modes.

The current speed shows that the speed display unit has two kinds of miles and kilometers, which can be set in the Settings. (See chapter 7 for details) the actual meter speed is only shown in one unit. It is impossible to show two units simultaneously. As shown in figure 6-5 :(figure 6-5 is only for illustration)

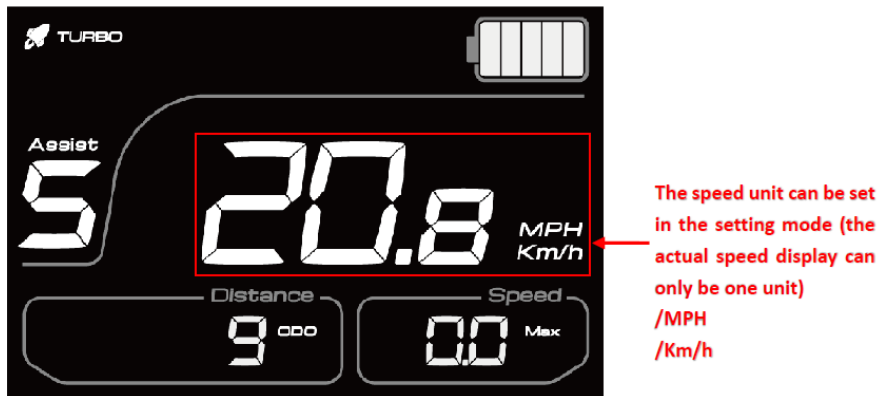

Figure 6-5

The total mileage is shown in figure 6-6:

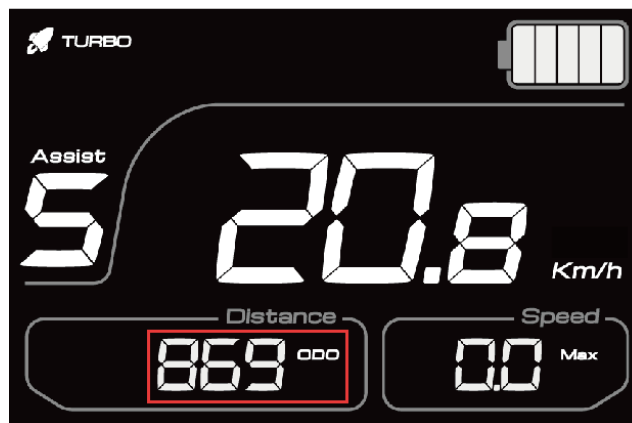

Figure 6-6

The single mileage display is shown in figure 6-7:

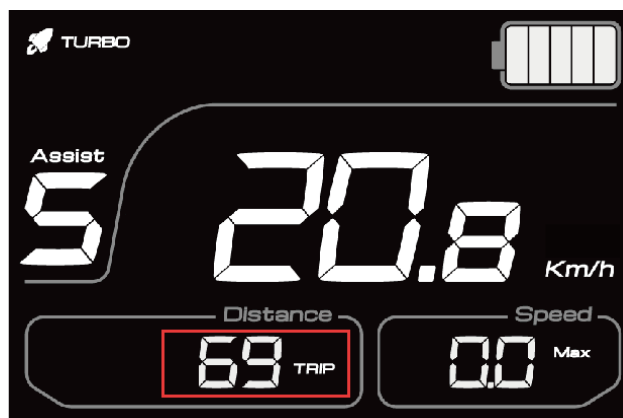

Figure 6-7

The gear display (figure 3 below) is shown in figure 6-8:

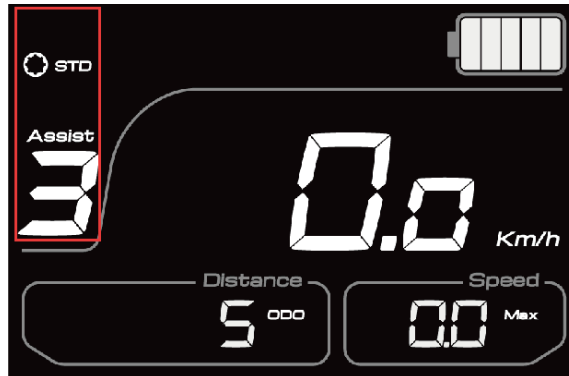

Figure 6-8

The battery power display (the current remaining power is 3) is shown in figure 6-9:



Figure 6-9

f. Electricity display

When the battery is full, the five parts are all bright; when the battery is under voltage, the last one flashes and needs to be recharged immediately. As shown in figure 6-10:



Figure 6-10

g. Error code display.

When the electric control system fails, the meter will automatically display the error code, and the error code will blink. And stop work, only when the fault exclusion can exit the fault display (even shut down the instrument without troubleshooting, cannot work normally after restarting the instrument), show the cause of the error can be found in the attachments error code definition table. The display error code is shown in figure 6-11:

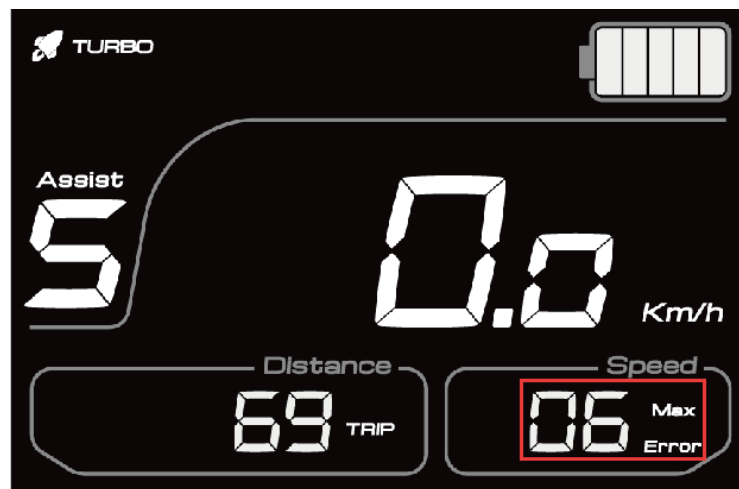

Figure 6-11

h. Motor power display

When the electric vehicle is riding, the controller will feedback the power of the motor to the meter, so that the meter can display the motor power in real time. The

riding power display is shown in figure 6-12:

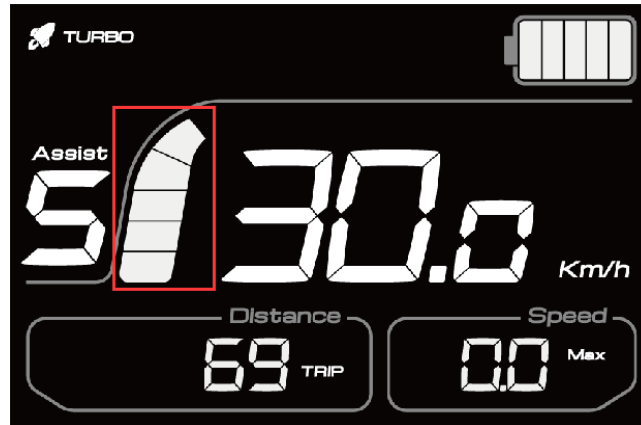

Figure 6-12

7、 General Setting

(1) Wheel diameter selection

Long press the setting key to enter the wheel diameter setting interface, with the following wheel diameter selection. As shown in fig.7-1:

WHEEL DIAM	
12	(957mm)
16	(1272mm)
18	(1350mm)
20	(1590mm)
22	(1770mm)
24	(1948mm)
26	(2072mm)
27	(2210mm)
28	(2260mm)
29	(2313mm)

Figure 7-1

By up and down the corresponding wheel diameter of the vehicle to ensure the accuracy of meter speed display and mileage display. If no operation is performed for up to 10 seconds, the dashboard will automatically exit the wheel diameter setting interface, and the factory default wheel diameter is 24C. The wheel diameter setting is shown in figure 7-2 :(the wheel diameter in the figure is 24C)

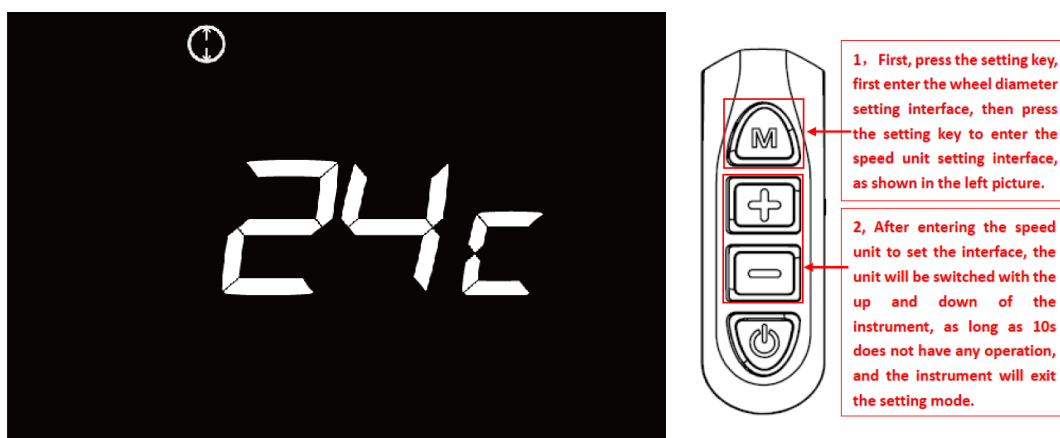

Figure 7-2

(2). Speed unit setting.

After pressing the setting key, the first step is to enter the wheel diameter setting interface, and then press the setting button to enter the setting interface of the speed unit. After entering the unit setting interface, the unit will be switched by adding and subtracting. There is no operation in 10 seconds, and the dashboard will automatically exit the speed setting interface. The unit switching Settings are shown in figure 7-3:

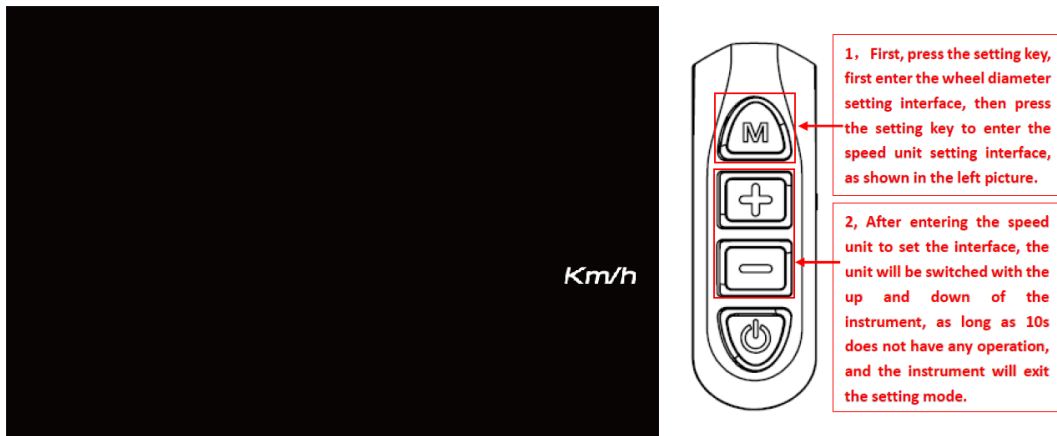

Figure 7-3

8、 Cable outlet define

CDC6 multi-function LCD display for the 8 pin Cable outlet define, the use of 24V/36V/48V battery voltage supply, followed by the power of the positive, ground, weak lock, turn the signal cable, communications R, communications T, 5V, light cable.

Cloud drive intelligent system wiring diagram: CDC6+ CDBL_C+ CDD4+ CD_2H18. As shown in the Figure 8:

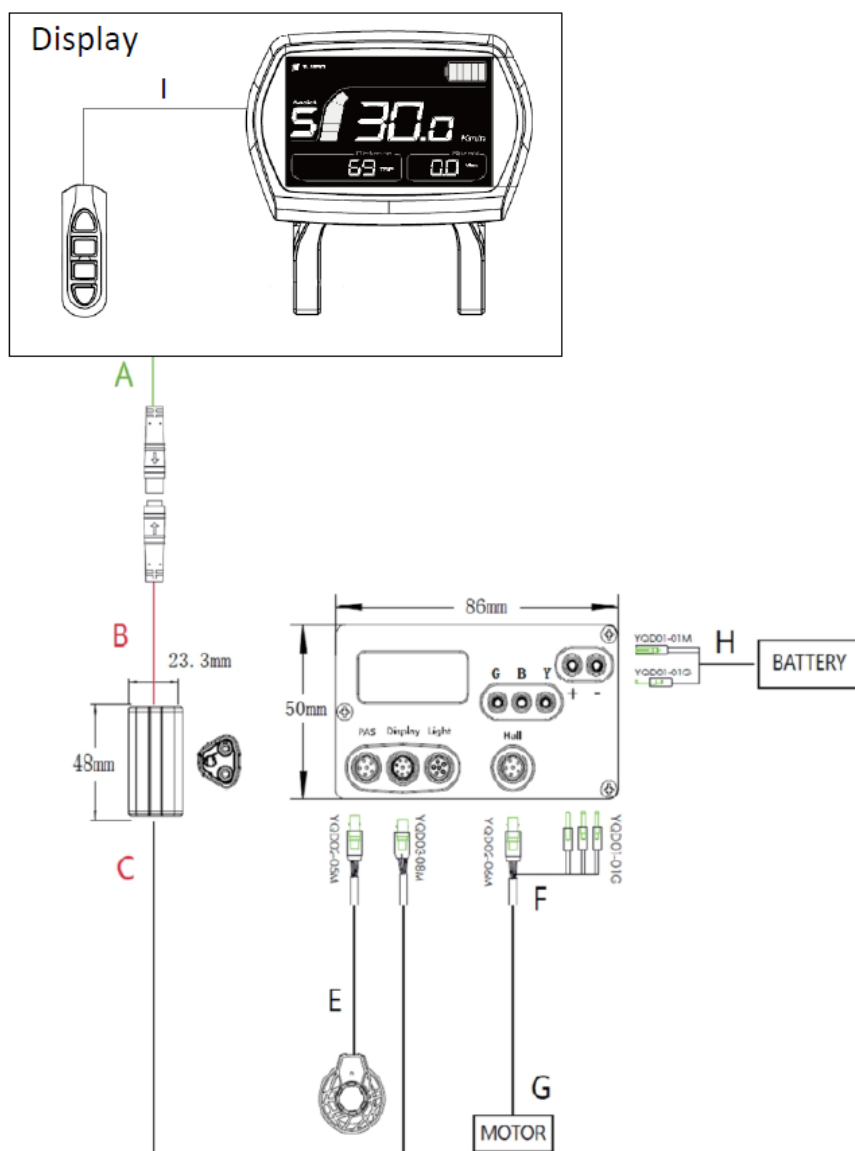

Figure 8

9、 Q&A

Q: Why the display is not able to start up?

A: Checking the connector that between display and controller.

Q: How to deal with the error code?

A: Fix it to the maintenance place immediately. If cannot be resolved, you can

go to the electric vehicle repair points repair it in a timely manner

Schedule: error code definition table

error code	definition
2	Overcurrent protection / motor Hall signal anomaly / controller internal power device / motor phase missing
3	Motor Hall signal abnormal / motor turn off stop protection / power supply terminal bad contact / control damage / motor damage
4	undervoltage protection
5	Brake abnormal (boot detection)
6	Abnormal motor Hall signal / motor damage
7	trottle abnormal (boot detection)
9	Abnormal voltage /trottle, sensor cable order wrong / 36V system assembly 48V battery
A/10	Display and controller communication yellow fault
F/15	Display and controller communication green fault

If the display and controller connected to the 5 pin cable failure:

Display can not boot, the screen is not displayed。 Possible cause: the main power supply cable is not connected well/ Controller phasemissing.

Display can be turned on, but after working 3 seconds stop working. Possible reasons: the display and the controller connected to the green, yellow cable of any 1 cables open.

