



CDC1 Specifications

Contents

1、	About the User Manual	3
2、	Characteristics	3
3、	Functions and Display	3
4、	Buttons	5
5、	Installation.....	5
6、	Functions	6
7、	Error codes	8

1、 About the User Manual

Dear users,

to ensure better performance of your e-bike, please read carefully through the CDC1 Specifications before using it.

2、 Characteristics

CDC1 products use the LCD display, double PCB, nylon buckle, ABS material shell and dip plastic parts (Figure 1).

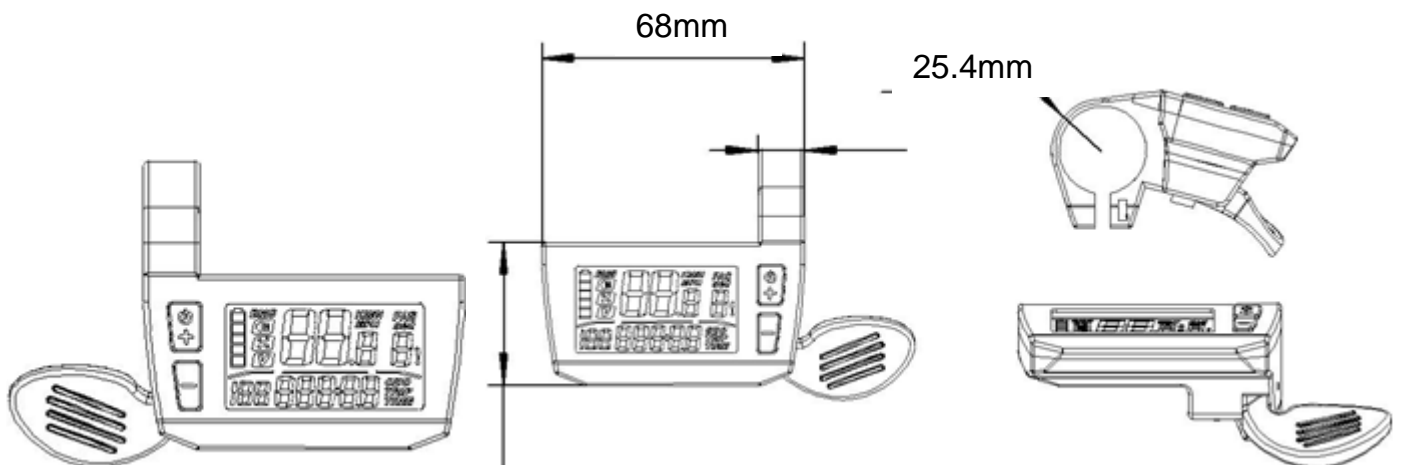

Figure 1

3、 Functions and Display

CDC1 is a Multifunction display with integrated throttle function. The same display can match 24V, 36V and 48V batteries.

CDC1 functions summary (Figure 2):

- Total distance indicator
- Riding distance indicator
- Current speed indicator
- Backlight indicator (switch backlight)
- PAS level selection
- Residual battery capacity indicator
- Error code definition
- Kilometers or miles
- Wheel diameter selection

Full Display

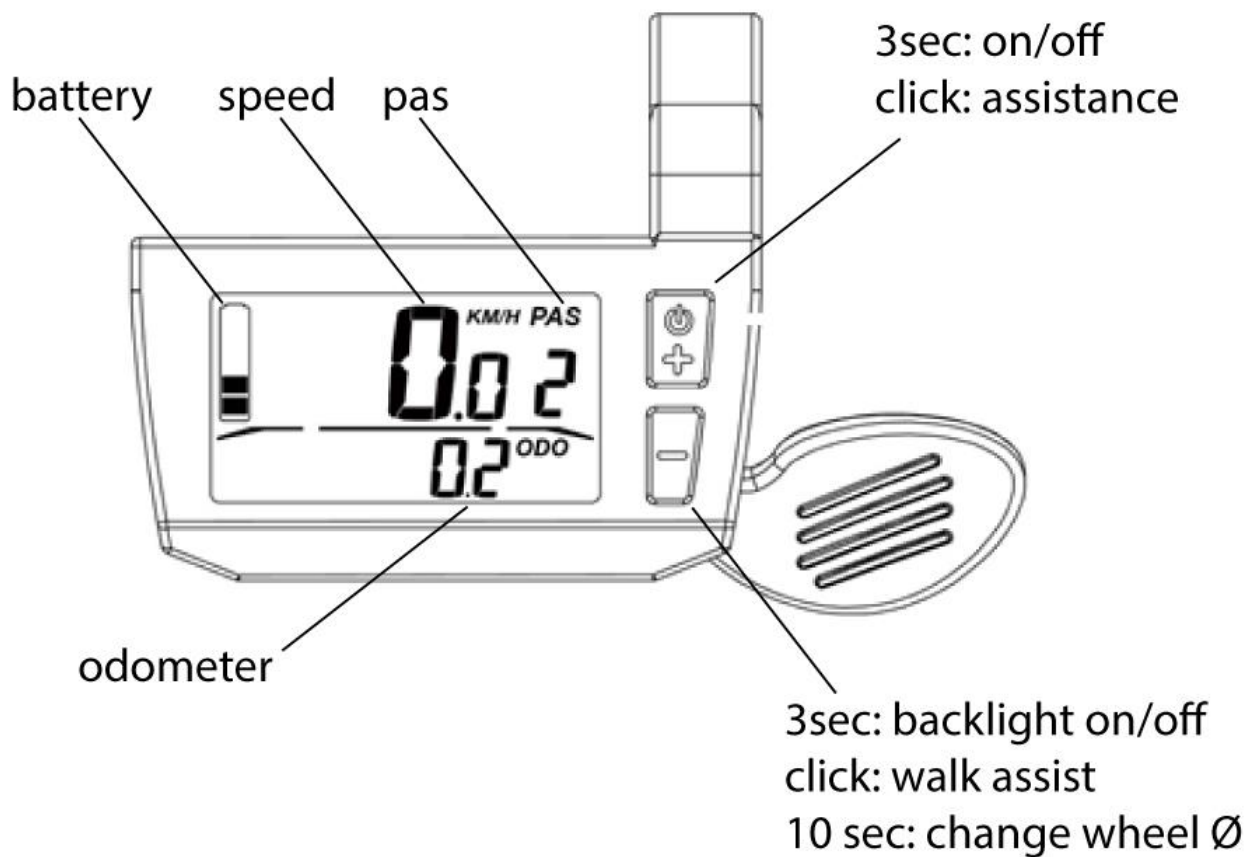

Figure 2

4、 Buttons

CDC1 has four buttons: ON/OFF, UP, DOWN and SET.

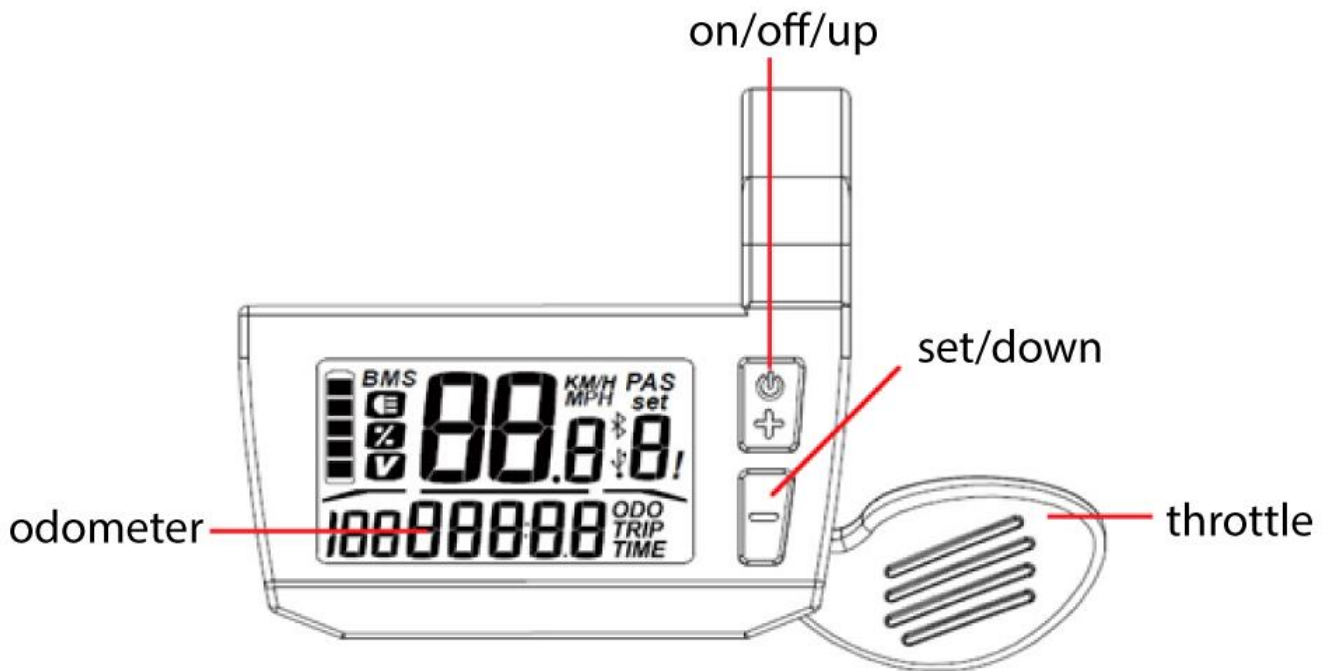

Figure 3

5、 Installation

Mount the display on the handlebar and then adjust the view angle. Tighten the screws to complete the installation (Figure 4 and 5):



Figure 4



Figure 5

6、 Functions

a. on/off

Press the UP button once to turn on the display. Press and hold the UP button for 3 seconds to turn off the display.

b. Backlight

Press and hold 3 seconds the “-” button to turn on or off the backlight.

c. PAS level selection

With the screen on, press the “+” or “-” buttons to increase or decrease the assistance levels from 0 (no power) to 5 (max power). While in 0 assistance level, hold the throttle to activate the walking assisted mode. This mode will help you push the e-bike by foot up to a maximum of 6 km/h speed.

d. Battery indicator

The residual charge of the battery is shown on the top-left part of the display. When the battery is full, the five notches are all bright; with low battery, the last one flashes and the battery needs to be recharged immediately. See Figure 6:

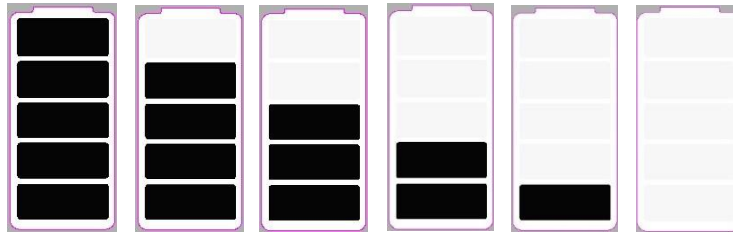

Figure 6

e. Wheel diameter selection

Press the SET button and hold for 5 seconds to open the bicycle setting interface, then press the SET button again until the wheel diameter setting interface is reached. The wheel diameter selection is shown in Figure 7:

With the - and + buttons select the new correct diameter. To choose a diameter other than the real one may cause malfunctions.

WHEEL DIAM	
12	(957mm)
16	(1272mm)
18	(1350mm)
20	(1590mm)
22	(1770mm)
24	(1948mm)
26	(2072mm)
27	(2210mm)
28	(2260mm)
29	(2313mm)

Figure 7

7、 Error codes

The error codes are shown at the top-right of the display. Check the following Table. In case of error, please contact the Technical Support.

Error code definition table

Error code	Description
2	Overcurrent protection / Motor's Hall signal anomaly / controller's internal power device / motor's phase missing
3	Motor's Hall signal anomaly / safety shutdown of the motor anomaly / bad contact of power supply terminal / damage control / motor damage
4	Low voltage
5	Faulty brakes sensor
6	Battery anomaly
7	Throttle anomaly
9	Voltage anomaly
A/10	Display and controller communication fault (yellow cable)
F/15	Display and controller communication fault (green cable)
Display does not turn on or shuts down after 3 second from turning on: please check that controller cables or supply power cables are well connected.	